



APOLLO

A630 APARTMENT COMPACTOR

FEATURES INCLUDE:

LARGE 30" x 30" CHARGING CHAMBER

1/4" INTEGRAL MAINFRAME / HOPPER

3/8" A.R. FLOOR PLATE

SINGLE SIDE LATCH OR BOTTOM LATCH
OPTIONS

DUAL 3" x 2" CYLINDERS

SINGLE PIECE RAM

80% & 100% FULL LIGHTS WITH
AUTOMATIC SHUTDOWN

CONTROL PANEL FEATURES:

KEY ON/OFF

AUTOMATIC PHOTO SENSOR OPERATION

MANUAL FORWARD REVERSE

EMERGENCY STOP BUTTON

POWER ON LIGHT

MICROPROCESSOR CONTROLS WITH
EASY READ OUT PROGRAMMING AND
TROUBLE SHOOTING

UL LISTED POWER PACK
FACTORY ASSEMBLED



A630-HF HAND FED
MODEL
30" x 30" ACCESS DOOR

**LARGE 30" x 30"
COMPACTION CHAMBER
NO MORE BRIDGING
OF GARBAGE**

PRODUCT DATA AND RATINGS A630

GENERAL

COMPACTOR MODEL	APOLLO A630
CHAMBER CAPACITY - MFR	0.44 CU.YDS
CHAMBER CAPACITY - WASTEC	0.37 CU.YDS
CHAMBER CLEAR TOP OPENING	31" L x 30.5" W
TOP OPENING	54"L x 30.5"W
RAM DIMENSIONS	18"H x 30.5"W
OVERALL DIMENSIONS	72"L x 36"W x 69"H
EST. SHIPPING WT.(INCL. POWER PACK)	1950 LBS

PERFORMANCE CHARACTERISTICS

CYCLE TIME	37 SECS.
CAPACITY PER HOUR	44 CU.YDS.
RAM FACE PRESSURE (N) @ 1600 PSI	41 PSI
RAM FACE PRESSURE (M) @ 1800 PSI	47 PSI
PACKING FORCE (N) @ 1600 PSI	22,500 LBS
PACKING FORCE (M) @ 1800 PSI	25,500 LBS

STRUCTURAL CHARACTERISTICS

MAIN FRAME & HOPPER	1/4" HRS PLATE
IMPACT PLATE - REINFORCED	1/4" HRS PLATE
FLOOR PLATE	3/8" A.R.PLATE
RAM FACE PLATE	3/8" HRS PLATE

ELECTRICAL SPECIFICATIONS

REMOTE POWER PACK DIMENSIONS	46"H x 22"W x 14"D
MOTOR	5HP
MOTOR POWER	208/230/460V, 3PH, 30 AMPS
CONTROL VOLTAGE	120VAC (24VDC OPTION)
CIRCUITS CONTROLLER	PLC PROCESSOR
MONITORS	80% & 100% FULL
PHOTO ELECTRIC EYE	OMRON E3K
DOOR SAFETY SWITCH	TELEMECANIQUE
CONTROL PANEL	UL LISTED

HYDRAULIC SPECIFICATIONS

CYLINDERS	3" BORE, 2" ROD
HYDRAULIC PUMP CAPACITY	6 GPM
OIL TANK CAPACITY	12 GALS.
OPERATING PRESSURE	1600 PSI
RELIEF PRESSURE	1800 PSI
MAXIMUM RATED PRESSURE	3000 PSI

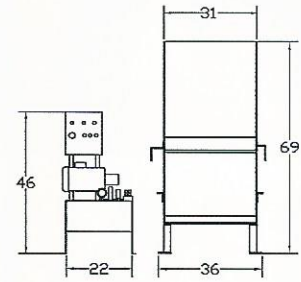

FRONT

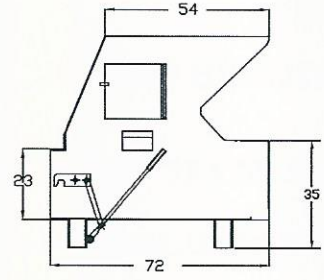

SIDE

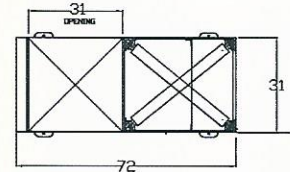

TOP SECTIONAL VIEW

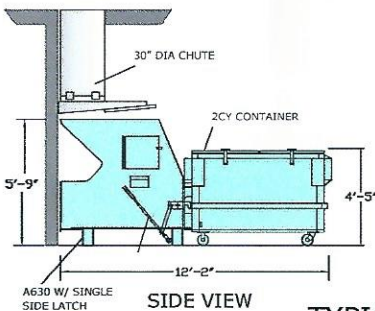

SIDE VIEW

TYPICAL LAYOUT A630

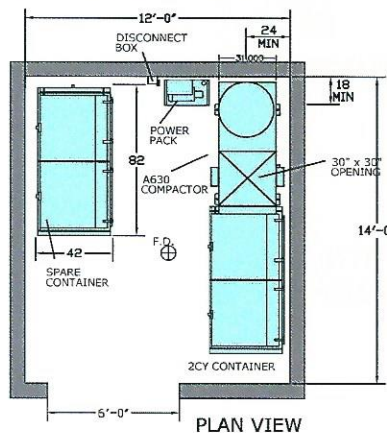

PLAN VIEW

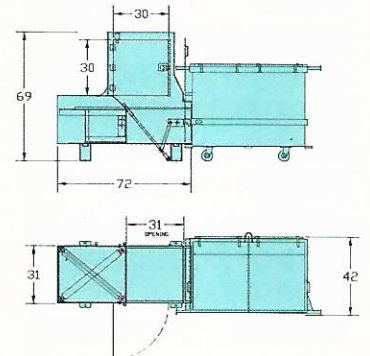

A630-HF LAYOUT WITH 2CY RL CONTAINER

APOLLO WELDING AND FABRICATING, INC.

35600 CURTIS BLVD, EASTLAKE, OHIO 44095

PH: 440 942 0227

FAX: 440 942 0127

apollo@apollowelding.com

www.apollowelding.com

DISTRIBUTED BY: